

500VA (SY0611-1411A1) Toroidal Auto Transformer

1、Diagram

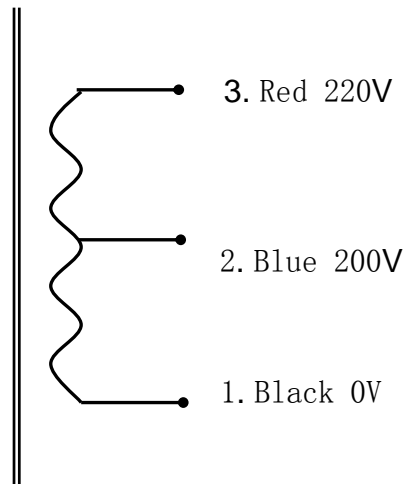

2、Performance

Name	Power (VA)	Outside Dimension		Weight (kg)	Pitch (mm)	Nut (mm)
		D(mm)	H(mm)			
Toroidal Auto Transformer	500	96	33	0.9	—	M8
Primary Rate Input			220V 50Hz			
Primary Direct Current Resistance			Ω			
No-load Current (Max)			20mA			
Secondary Rate Output						
	No-load Voltage (V±5%)	Load Voltage (V±5%)		Rated Load Current (A)		
S1: 1~2	0~200	—		2.5		
Lead Wire Specification						
	Color	Specification	Length (mm)	Terminal		
Primary Lead Wire: 1~3	Black-Red	RVV-0.75	200	Tin Imbrued 5mm		
Secondary Lead Wire: 1~2	Black-Blue	RVV-0.75	200	Tin Imbrued 5mm		